



Korea and Incheon City Auto Industry Overview & Incheon Auto-parts Industry Clustering & Export Support Program

December 2008



재단
법인 **송도테크노파크**
SONGDO TECHNOPARK

Auto Industry is to lead Korean Economy

Production Amount	12% of Total Manufacturing Industry	US\$98Bils(2005)
Export Amount	13% of Total Export	US\$4.3Bils(2006)
Trade Income & Expenditure	228% of Total Trade Income	US\$3.7Bils(2006)
Tax Revenue	16% of Total Tax Revenue	US\$26Bils(2005)
Hiring	8.8% of Total Manufacturing Industry	253,000(2005)



Car Production Trend in Korea

'1994~'2005

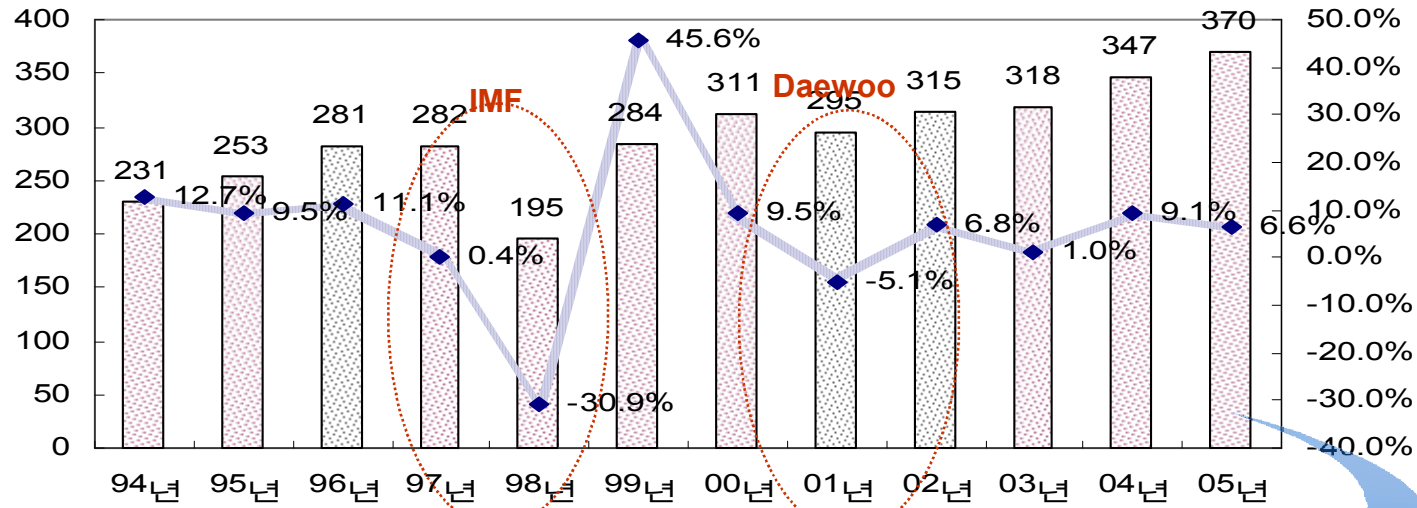

SAMSUNG RENAULT

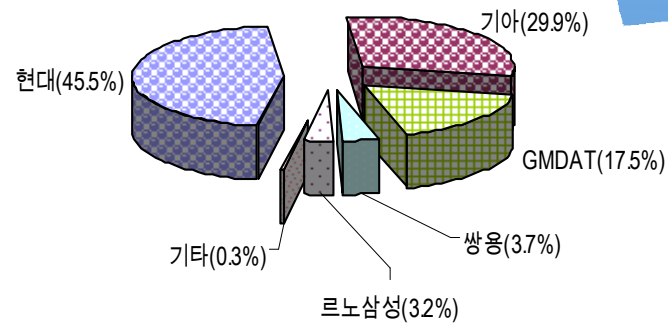

Korean Major Auto-parts Company in Global Ranking

World-leading Auto-parts Companies

- Toyota : Denso/Asin → Powertrain Parts (Transmission, Power train) own Tech. and Patent
- Mercedes : Bosch → Common Rail Engine Development

R&D budget is expanding for cutting-edge competitive in Global Market

- World 100 Largest Auto parts Company : Hyundai is ranked 25th, Mando 84th

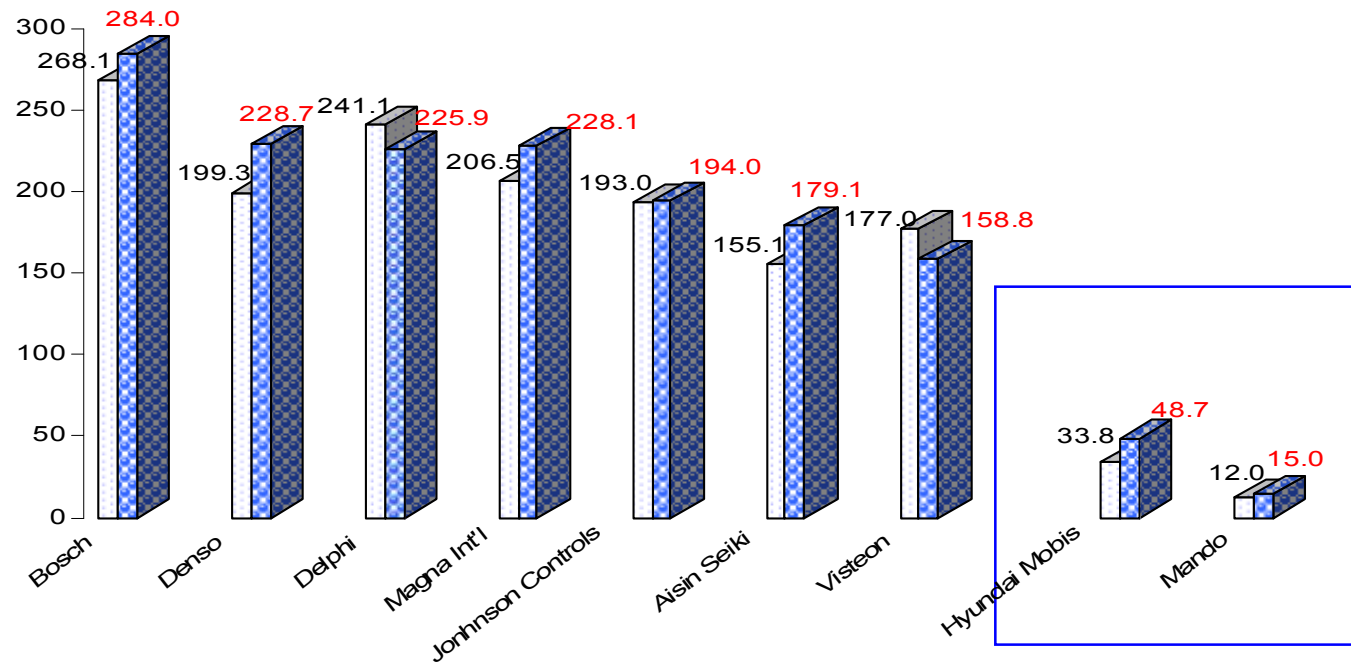

Auto-parts Industry in Incheon City

Location Benefits

- Maker : GM-DAT with 500,000 Car Production Capacity
- 1,700 Auto-parts Companies including 3rd-tier
- Center of Logistics and Manufacturing Industry
 - Incheon Int'l Airport, Incheon Port, Free Economic Zone, 2nd Subway, New Port, 2nd & 3rd Express Way, etc.
 - 7 Industrial Complexes in Incheon City, over 9,000 Companies

Auto Industry

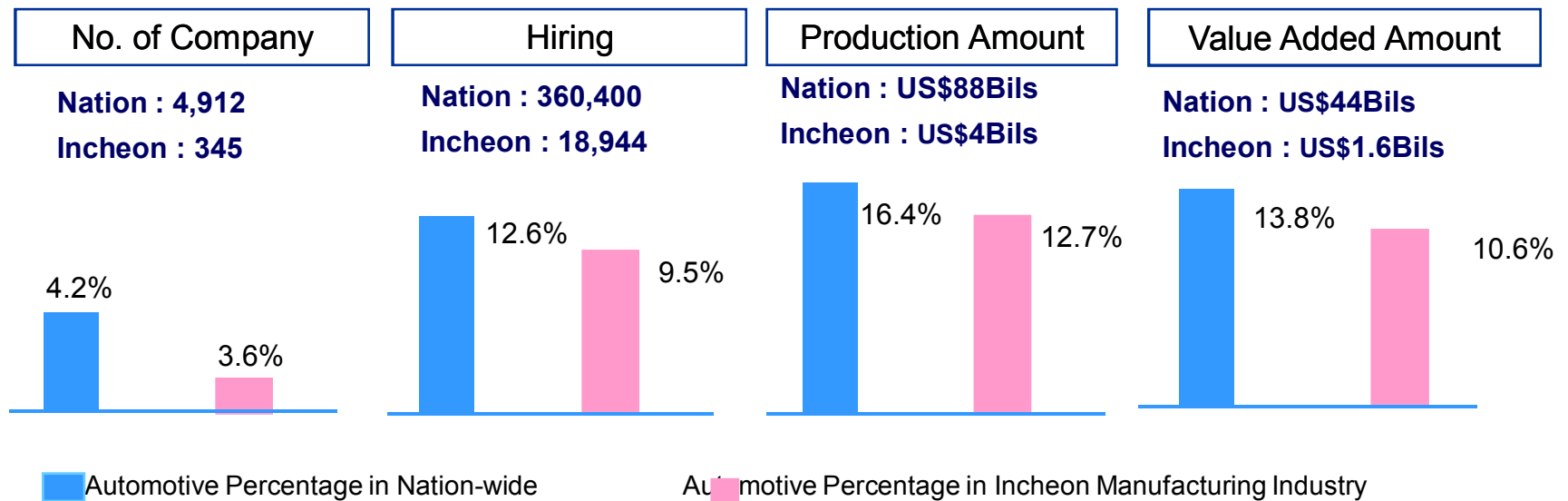

Auto-parts Industry in Incheon City

Unit : US\$

		'01	'02	'03	'04	'05
Production Amount	amount	2.7Bils	3.1Bils	3.6Bils	3.6Bils	4.0Bils
	Percentage in manufacturing sector	7.7%	8.4%	9.4%	8.2%	8.7%
	Growth Ratio	-20.9%	14.2%	17.0%	0.8%	11.9%
Hiring	Numbers	16,626	21,811	21,450	20,687	18,944
	Percentage in manufacturing Industry	8.3%	10.5%	10.1%	10.0%	9.5%
	Growth Ratio	-24.9%	31.2%	-1.7%	-3.6%	-8.4%
Value added Amount	amount	0.7Bils	0.8Bils	1.2Bils	1.5Bils	1.6Bils
	Percentage in manufacturing Industry	5.8%	6.1%	8.6%	9.4%	10.6%
	Growth Ratio	-8.6%	10.9%	50.7%	21.0%	9.5%

Program Overview

❖ Overview

- ◆ Name : Incheon Auto-parts Industry Clustering & Export Support Program
- ◆ Period : 2005 ~ 2010 (6 years)
- ◆ Total Fund : US\$10Mils.
- ◆ Main Bodies
 - Central Government : The Ministry of Knowledge Economy (US\$5Mils.)
 - Local Government : Incheon City Government (US\$2Mils.),
 - Private Sectors : (US\$3Mils.)
 - Management : Songdo Technopark
- ◆ Participants : Korea Industrial Technology Institute, Incheon Uni., Inha Uni., Etc.

❖ Goals

- ◆ Support to Maximize Exports for Auto-parts Companies
- ◆ Improve Quality and Reduce Cost to Achieve Global-level Competence
- ◆ Attract Top-level Auto-parts R&D Centers in Incheon Region
- ◆ Select and Support Pre-Star Companies and Foster Star Companies
- ◆ Train Designers and Engineers to Achieve Global-level Competence

Program Overview

❖ Project Concept

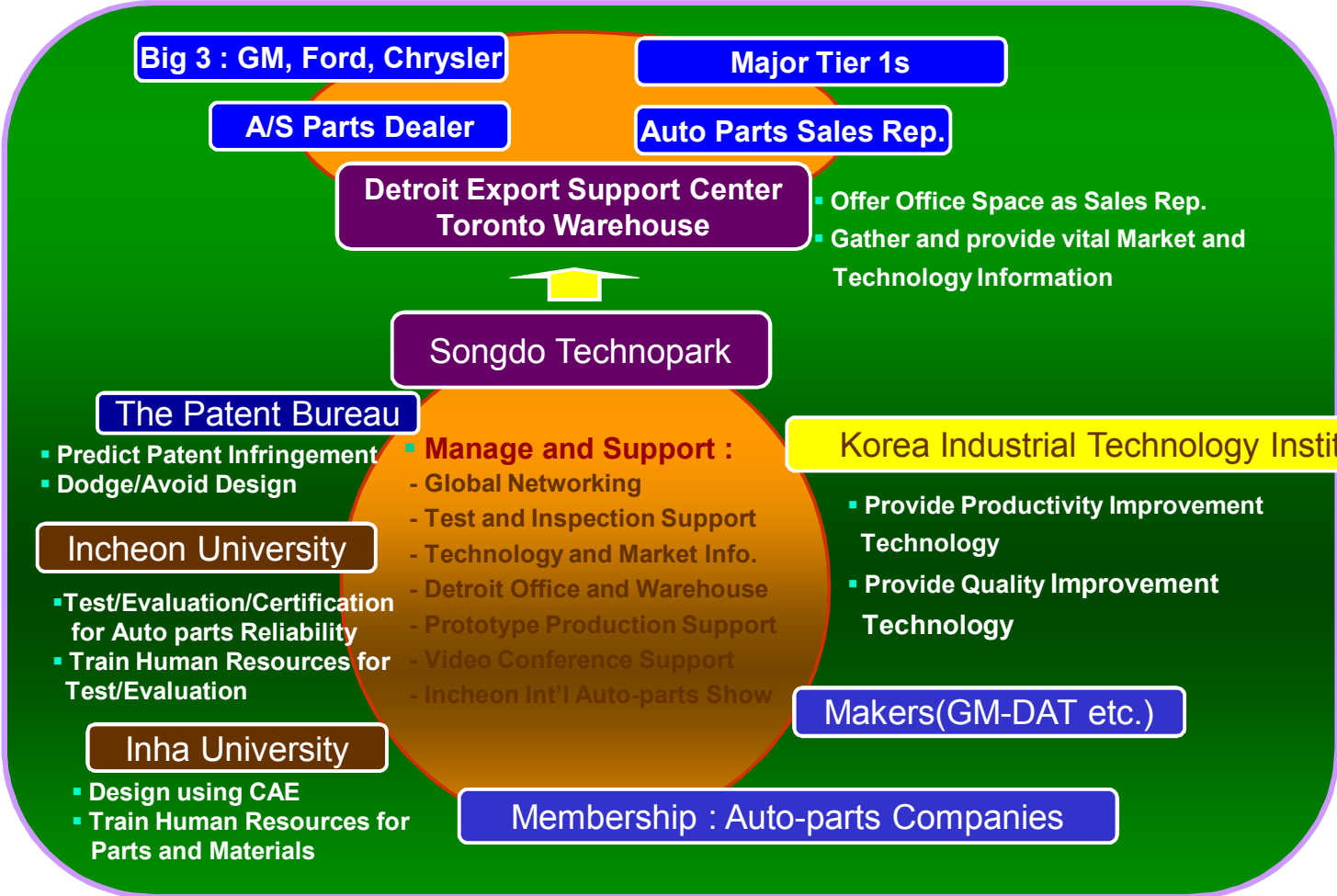

❖ Economic Result of the Program : US\$81Mils.

- Export Support (Examples) : US\$1.23Mils.
 - Platec Co., Ltd. : US\$0.3Mils
 - Export “Door Handel Dies” with 6 other Dies to Poland, Uz
 - Cooling Systems Co., Ltd. : US\$0.7Mils
 - Export “Fan Clutch” to GM and 1-tier vendors
 - Ajin Co. : US\$0.13Mils ordered
 - Bendasun Co., Ltd. : US\$0.13Mils ordered
 - etc.
- Technology & Design Development & Support : US\$48Mils
- Training and Networking: US\$21Mils
- Consulting, Info. Exchange and Promotion : US\$10.77Mils

Global Network

❖ Export Support Center in Detroit, US & Warehouse in Toronto, Canada

- Export Support by Industry Specialists
- Offer Office Space for Incheon Auto-parts Companies
- Address : 1700 Towncenter 4000, Southfield, Michigan, US



❖ Dual Video Conference System with T1 Dedicated Network

- Support communication for business meetings between Two Countries
- Location : Songdo Technopark in Incheon, Korea and Export Support Center in Detroit, US

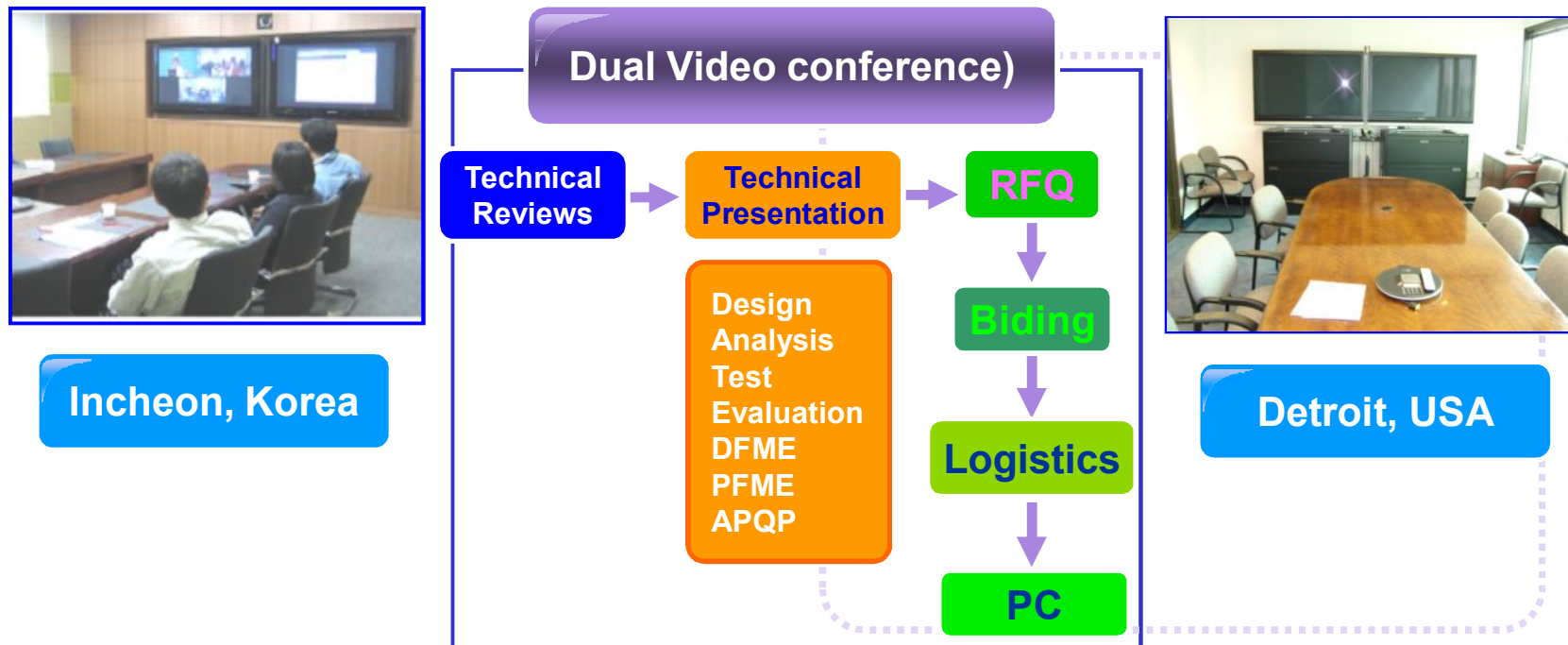

❖ Sales/Cooperative Network in Detroit, US

- C. T. Charlton & Associates, Inc. : One of the biggest Sales Rep. in US
- Terry Barr Sales Rep.
- DRC (Detroit Region Commerce) : over 2,400 Membership Companies

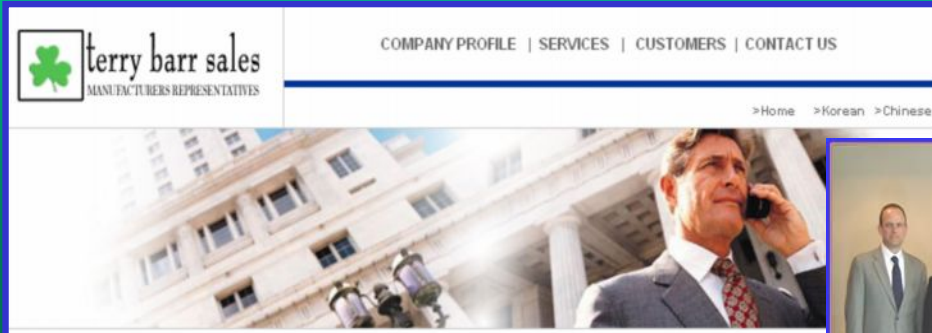

Result (Product Development)

- ❖ Pre-Star Company Selection : 14
- ❖ SOR Analysis Support : 16
- Quotation & CAD drawing Support and F/up
 - Korea Wheels Co.(Aluminum Wheels) for GM
 - Doosung MB Tech Co. and Myung-hwa Co. (Drum Brakes) for MAN
 - Hanjin Diecasting Co., Kodako Co. and Myung-hwa Co.(Engine Parts) for MAN
 - Korea Wheels Co.(Steel Wheels for Bus, Trucks) for MAN
 - Door Inner Handle for GM

- ❖ Tech Support for Global Sourcing

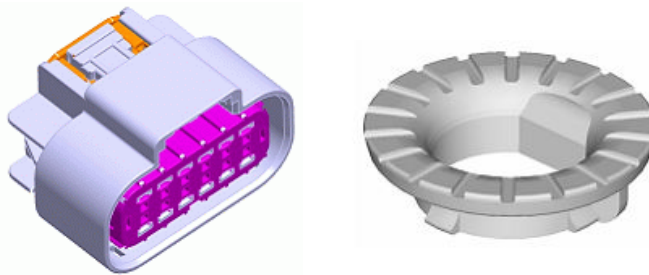

- ❖ Pilot Project for Pre-Star Company
 - Pratec Co., Ltd.
 - for Side Mirror Rear Vision Check
 - Result : Export to GM Poland

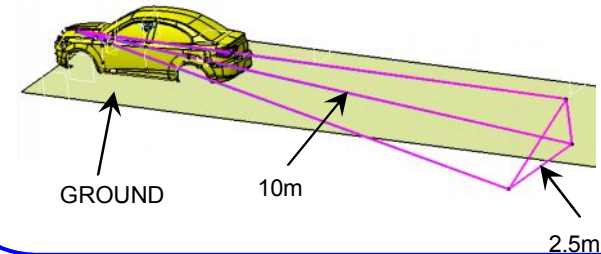

- ❖ Technology Problem Solving (31), Part Design (16), Test (28), Patent (8), Proto Type (17)), Training (12)

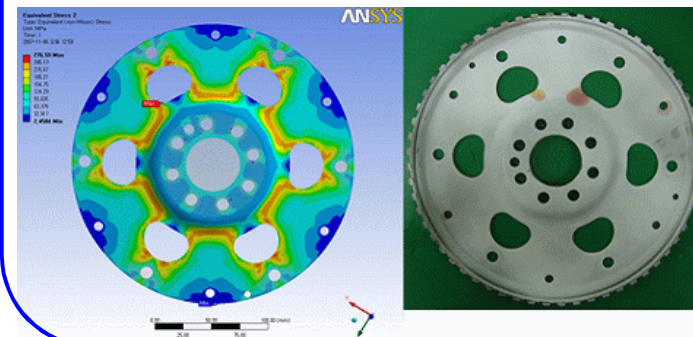

Result (Test and Inspection)

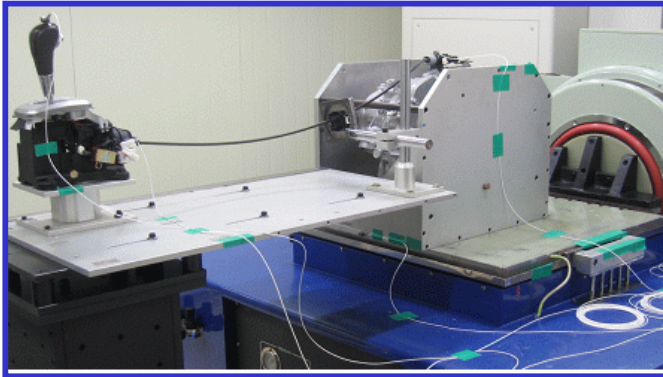

Daedong Systems Co., Ltd. for GM-DAT
: Transmission Cable Vibration Test



Daewon Machinery Co.,Ltd. for GM-DAT
: Stabilizer Bar Duality Test

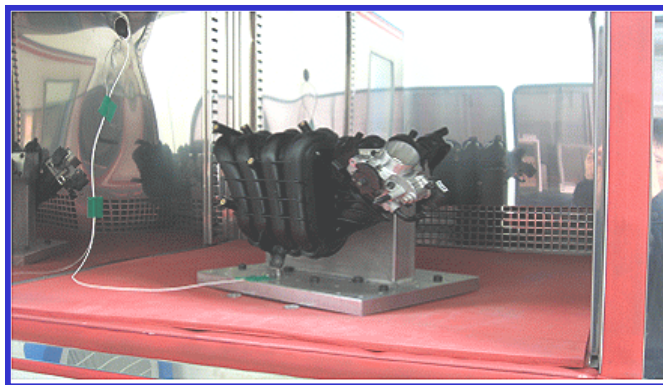

Inji Controls Co., Ltd. for Hyundai Motor
: Intake Manifold Vibration Test

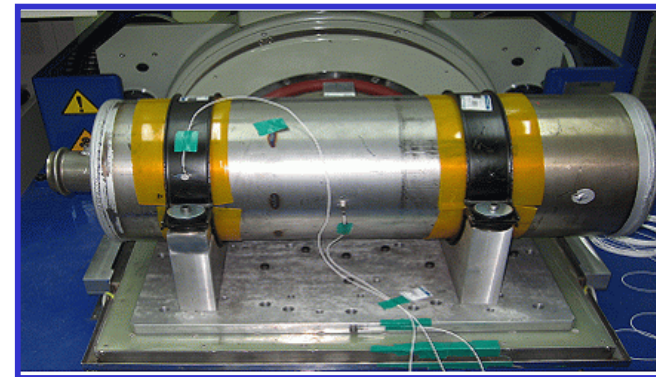

Daeji Metal Co., Ltd. for Doosan Infracore
: Muffler Vibration Test

Result (Design & Prototype)

❖ LED Lamp Design & Die-casting



❖ Differential Carrier 3D Model

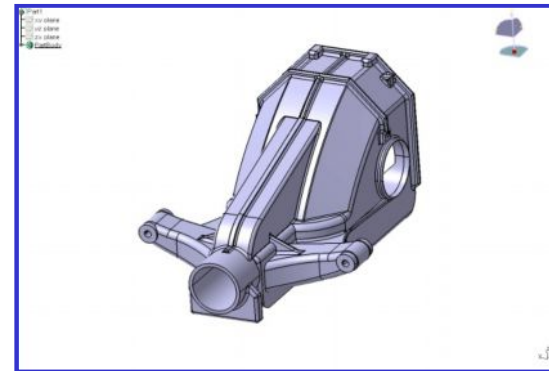

❖ Differential Carrier Prototype



❖ Air-duct and Interior Parts



Result (Training & Info. Exchange)

- ❖ Test and CAE Tech. Seminar
- ❖ CEO Gathering Meeting : 7 times



- ❖ News Letters for Human Resources /Facilities/Training : 20 times/Month



- ❖ KOLAS Reliability Evaluation Support
- MOU made with Japan Auto-welding Company for Tech. Assistance and Cooperation



- ❖ Tech. Consulting by On-line System : 22 times
- ❖ Tokyo Motor Show



Result (Training & Info. Exchange)

❖ Reliability Test and Inspection
- AutoCAD, Excel VBA, FMEA, DISC



❖ APQP Project Manager Training
- 108 times, 2377 persons



❖ Design & Analysis Training
- CATIA, ANSYS, STAR-CD, Mold-flow,



❖ Website and News-letter Publication



Result (Promotion)

❖ 2007 North America Testing EXPO

- 10. 24th.~ 26th.
- Hydraulic Vibration Test : 30 times



❖ Export Support Office Promotion

- 2007, 2008, 2009 Incheon Auto-parts Show
- 65 Auto-parts Companies Directory



❖ 2008 Int'l Parts Industry Show

- April 29th. ~ May 1st.



❖ 2008 SAE World Congress

- April 14th. ~ April 17th.

